



» play » multiplay systems products » unimini products » unimini sandcausa



UniMini SandCausa

8074053



UniMini SandCausa, the ultimate sand play unit designed to provide an immersive and interactive sand play experience for children aged 3 to 5 years. This engaging playset features a crane hoist, sand hopper, sand table, and interactive elements, offering endless possibilities for imaginative play and sensory exploration.

S Wooden Posts / HPL Panels
Red – Sunken Foundation

★ 6300 x 5650

Icon Guide



Age Range



No. of Users



Assembly time



Free height of fall EN1176



Impact area EN1176



Accessible



Space needed



HAGS®

Technical Information

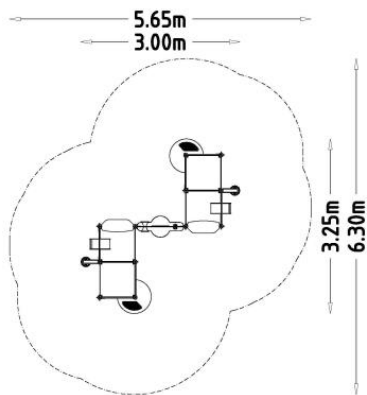
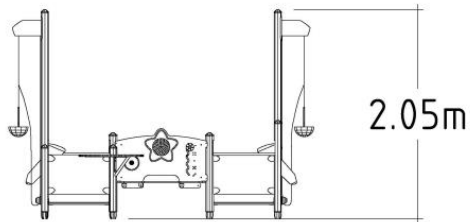

Anchoring

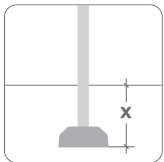

S Sunken Foundation

Technical Information

[Download product installation guide](#)

[Download inspection and maintenance guide](#)

Product Specifications

Age Range:	3-5
Length (mm):	3000 mm
Width (mm):	3250 mm
Height (mm):	2050 mm
Net Weight:	204,986 kg
Safety Area Width (mm):	6300 mm
Safety Area Length (mm):	5650 mm
Safety Area :	27 m ²
Fall Height (mm):	600 mm
Assembly Time:	19,26 hours

Product Materials

Material	kg	%
Aluminum	0	0
HPL	149,3	49,8
Pine	34,9	11,6
Polyamide (PA)	2,5	0,8
Polyethylene (PE)	2	0,7
Polyurethane solid (PUR)	0,6	0,2
Powder coating polyester	1,7	0,6
Rubber	0,2	0
Stainless steel	0,2	0,1
Stainless steel EN 1.4301	7,2	2,4
Untreated Steel	97,7	32,6
Wet paint for wood	1,8	0,6
Zink (electro-galvanised)	0	0
Zink (hot-galvanised)	1,5	0,5
	300 kg	100%



HAGS®

Materials

Our most common materials



Structural Steel is the ultimate recyclable choice. Our steel, which can be 100% reclaimed at the end of life, is built to last for generations, continuously rejoining the supply chain. Its durability, enhanced by our protective coatings, ensures a long lifespan, reducing ownership costs.



Nordic Pine Wood is responsibly sourced from certified Scandinavian forests. Our wood products, using this 'slow grown' Pine are known for their durability, with extended warranties. This aligns with sustainability practices, and HAGS' mission for environmental responsibility through carbon absorption and recyclability.



High Pressure Laminate (HPL) incorporates recycled materials into our play equipment and furniture products, offering fire and slip resistance, texture, and choice of colour. With up to 34% SCS-Certified recycled content, our HPL exceeds wear and impact resistance standards, ensuring exceptional lifetime value.



FSC Certified Hardwood in various furniture products, signify a dedication to sustainability and quality. Renowned for durability and attractiveness, our hardwoods show excellent natural resistance to decay and insects, making them ideal for outdoor furniture.



Steel Core Rope offers exceptional durability, UV stability, and a soft touch for users. Our customers will benefit from our in-depth expertise in ropes, connectors, and end fittings, ensuring they receive knowledgeable guidance tailored to their playground needs.



Recycled Plastic, EcoGrip used by HAGS, comprises 89% recycled polyethylene with a 2mm thick layer on one side. Some furniture pieces feature recycled polyethylene slats. Plastic components can be reclaimed at the end of life, being sorted by type, for optimal future recycling.



Aluminium which is present in some HAGS products, utilises EN AW6060 T6 quality in extruded profiles, often treated with anodizing. Its high recycled content and ability to be reclaimed at the end of life, reduces environmental impact.



Rubber, synthetic (EPDM or SBR) or natural, excels at absorbing vibrations for impact dampers. HAGS uses reclaimed car tires for swing seats, ensuring an eco-friendly second life and safety by selecting tires made post-January 2010, complying with REACH requirements.



Fasteners are the collective name for all types of bolts, nuts and rivets etc. available from HAGS. Our fasteners have an important function to fulfil, so we place great emphasis on having the right type and high-quality fasteners.