



- » sport fitness » outdoor gym and fitness equipment » hags fitness equipment » hags leg press
- » cast in place yellow



### HAGS Leg Press

8073904



**CC** Yellow – Cast In Place

 4240 x 4380

The Leg Press helps to build strength and endurance in the hamstring, calves, quadriceps and gluteal muscles, whilst keeping your back supported. Designed for up to 2 users at a time, it allows for people to exercise next to each other, which is great for that extra (usually much needed) motivation and support. The Leg Press is safe, easy-to-use and is built with easy access seats.

### Icon Guide



Age Range



No. of Users



Assembly time



Free height of fall EN1176



Impact area EN1176



Accessible



Space needed



# HAGS®

## Technical Information

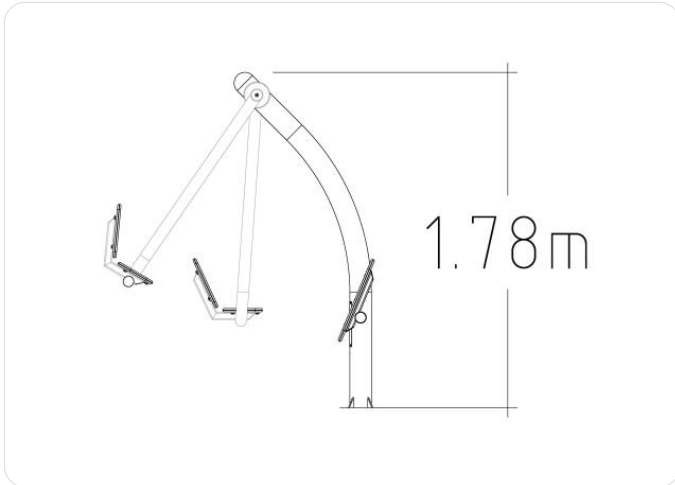

### Product Specifications

<b>Length (mm):</b>	1250 mm
<b>Width (mm):</b>	940 mm
<b>Height (mm):</b>	1780 mm
<b>Net Weight:</b>	130 kg
<b>Safety Area Width (mm):</b>	4240 mm
<b>Safety Area Length (mm):</b>	4380 mm
<b>Safety Area :</b>	17 m <sup>2</sup>
<b>Fall Height (mm):</b>	700 mm

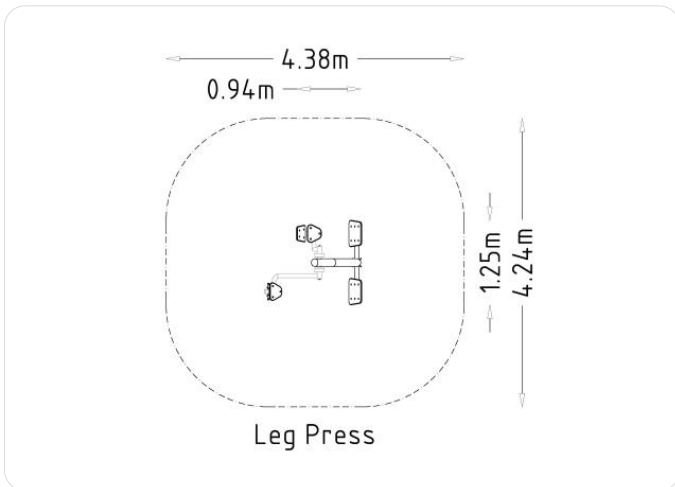

### Anchoring

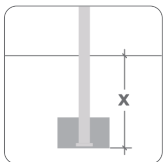

**CC** Cast In Place

### Technical Information

- [Download product installation guide](#)
- [Download inspection and maintenance guide](#)



# HAGS®

## Materials

### Our most common materials



**Structural Steel** is the ultimate recyclable choice. Our steel, which can be 100% reclaimed at the end of life, is built to last for generations, continuously rejoining the supply chain. Its durability, enhanced by our protective coatings, ensures a long lifespan, reducing ownership costs.



**Nordic Pine Wood** is responsibly sourced from certified Scandinavian forests. Our wood products, using this 'slow grown' Pine are known for their durability, with extended warranties. This aligns with sustainability practices, and HAGS' mission for environmental responsibility through carbon absorption and recyclability.



**High Pressure Laminate (HPL)** incorporates recycled materials into our play equipment and furniture products, offering fire and slip resistance, texture, and choice of colour. With up to 34% SCS-Certified recycled content, our HPL exceeds wear and impact resistance standards, ensuring exceptional lifetime value.



**FSC Certified Hardwood** in various furniture products, signify a dedication to sustainability and quality. Renowned for durability and attractiveness, our hardwoods show excellent natural resistance to decay and insects, making them ideal for outdoor furniture.



**Steel Core Rope** offers exceptional durability, UV stability, and a soft touch for users. Our customers will benefit from our in-depth expertise in ropes, connectors, and end fittings, ensuring they receive knowledgeable guidance tailored to their playground needs.



**Recycled Plastic**, EcoGrip used by HAGS, comprises 89% recycled polyethylene with a 2mm thick layer on one side. Some furniture pieces feature recycled polyethylene slats. Plastic components can be reclaimed at the end of life, being sorted by type, for optimal future recycling.



**Aluminium** which is present in some HAGS products, utilises EN AW6060 T6 quality in extruded profiles, often treated with anodizing. Its high recycled content and ability to be reclaimed at the end of life, reduces environmental impact.



**Rubber**, synthetic (EPDM or SBR) or natural, excels at absorbing vibrations for impact dampers. HAGS uses reclaimed car tires for swing seats, ensuring an eco-friendly second life and safety by selecting tires made post-January 2010, complying with REACH requirements.



**Fasteners** are the collective name for all types of bolts, nuts and rivets etc. available from HAGS. Our fasteners have an important function to fulfil, so we place great emphasis on having the right type and high-quality fasteners.