

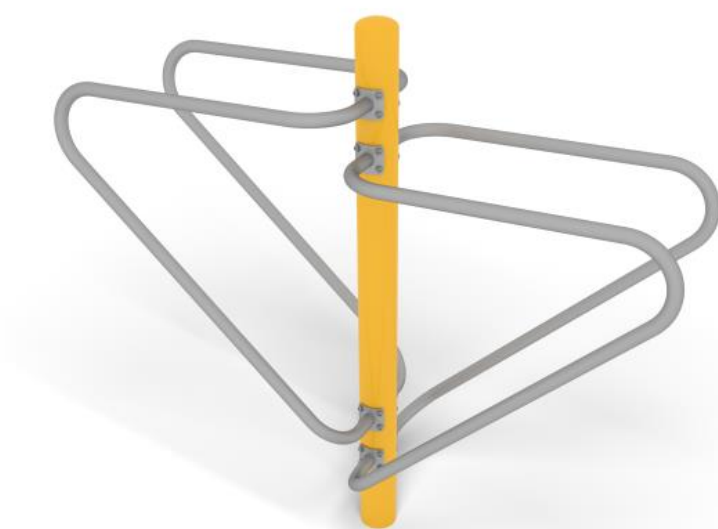

- » sport fitness » outdoor gym and fitness equipment » hags fitness equipment » hags parallel rails
- » cast in place yellow



### HAGS Parallel Rails

8061988

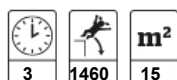

These Parallel Rails allows you to perform various exercises and work on different muscle groups. Primarily, it helps to develop upper body muscles such as the chest, shoulders and upper arms, but it can also be used to work on the lower back, abdominal muscles and leg strengthening. A great addition to any outdoor gym area.



### Icon Guide



Age Range



No. of Users



Assembly time



Free height of fall EN1176



Impact area EN1176



Accessible



Space needed



# HAGS®

## Technical Information

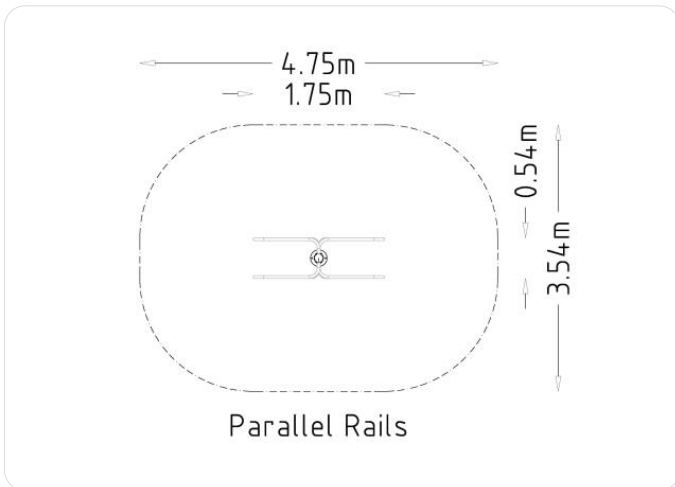
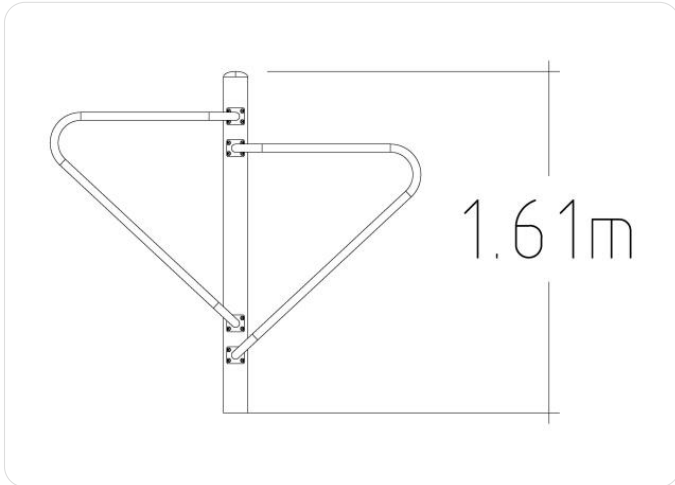

### Product Specifications

Length (mm):	1750 mm
Width (mm):	540 mm
Height (mm):	1740 mm
Net Weight:	159 kg
Safety Area Width (mm):	3540 mm
Safety Area Length (mm):	4750 mm
Safety Area :	15 m <sup>2</sup>
Fall Height (mm):	1460 mm
Assembly Time:	3 hours

### Product Materials

Material	kg	%
Aluminum	0,1	0
Powder coating polyester	0,2	0,2
Powder Coating primer	0,2	0,2
Stainless steel	1,5	1
Untreated Steel	156,4	98,7
	<b>158 kg</b>	<b>100%</b>

### Anchoring

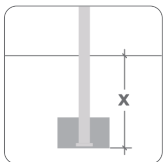

**CC** Cast In Place

### Technical Information

- [Download product installation guide](#)
- [Download inspection and maintenance guide](#)



# HAGS®

## Materials

### Our most common materials



**Structural Steel** is the ultimate recyclable choice. Our steel, which can be 100% reclaimed at the end of life, is built to last for generations, continuously rejoining the supply chain. Its durability, enhanced by our protective coatings, ensures a long lifespan, reducing ownership costs.



**Nordic Pine Wood** is responsibly sourced from certified Scandinavian forests. Our wood products, using this 'slow grown' Pine are known for their durability, with extended warranties. This aligns with sustainability practices, and HAGS' mission for environmental responsibility through carbon absorption and recyclability.



**High Pressure Laminate (HPL)** incorporates recycled materials into our play equipment and furniture products, offering fire and slip resistance, texture, and choice of colour. With up to 34% SCS-Certified recycled content, our HPL exceeds wear and impact resistance standards, ensuring exceptional lifetime value.



**FSC Certified Hardwood** in various furniture products, signify a dedication to sustainability and quality. Renowned for durability and attractiveness, our hardwoods show excellent natural resistance to decay and insects, making them ideal for outdoor furniture.



**Steel Core Rope** offers exceptional durability, UV stability, and a soft touch for users. Our customers will benefit from our in-depth expertise in ropes, connectors, and end fittings, ensuring they receive knowledgeable guidance tailored to their playground needs.



**Recycled Plastic**, EcoGrip used by HAGS, comprises 89% recycled polyethylene with a 2mm thick layer on one side. Some furniture pieces feature recycled polyethylene slats. Plastic components can be reclaimed at the end of life, being sorted by type, for optimal future recycling.



**Aluminium** which is present in some HAGS products, utilises EN AW6060 T6 quality in extruded profiles, often treated with anodizing. Its high recycled content and ability to be reclaimed at the end of life, reduces environmental impact.



**Rubber**, synthetic (EPDM or SBR) or natural, excels at absorbing vibrations for impact dampers. HAGS uses reclaimed car tires for swing seats, ensuring an eco-friendly second life and safety by selecting tires made post-January 2010, complying with REACH requirements.



**Fasteners** are the collective name for all types of bolts, nuts and rivets etc. available from HAGS. Our fasteners have an important function to fulfil, so we place great emphasis on having the right type and high-quality fasteners.